

# Unit 1

- |   |                                   |
|---|-----------------------------------|
| <b>1.1</b> Circles                        | <b>1.10</b> Numbers 1 and 2       |
| <b>1.2</b> big – medium – small           | <b>1.11</b> a lot of – a few      |
| <b>1.3</b> one – a lot of                 | <b>1.12</b> Patterns              |
| <b>1.4</b> Color sequences                | <b>1.13</b> Numbers 3 and 4       |
| <b>1.5</b> Numbers 1 and 2                | <b>1.14</b> Squares               |
| <b>1.6</b> inside – outside               | <b>1.15</b> Number review: 1 to 4 |
| <b>1.7</b> Numbers 1 and 2                | <b>1.16</b> Matching shapes       |
| <b>1.8</b> Characteristics                |                                   |
| <b>1.9</b> Big, medium, and small circles |                                   |

© Richmond Publishing  
This free sample content  
is for teacher review only  
and may not be copied or sold.

# Circles

1.1

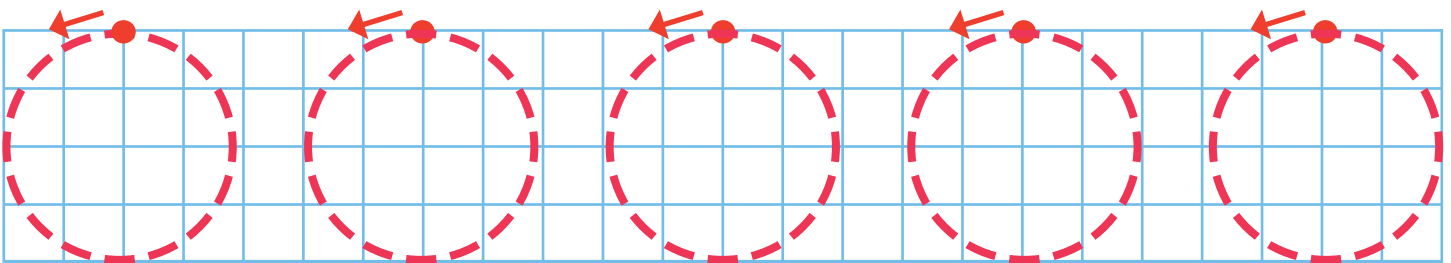
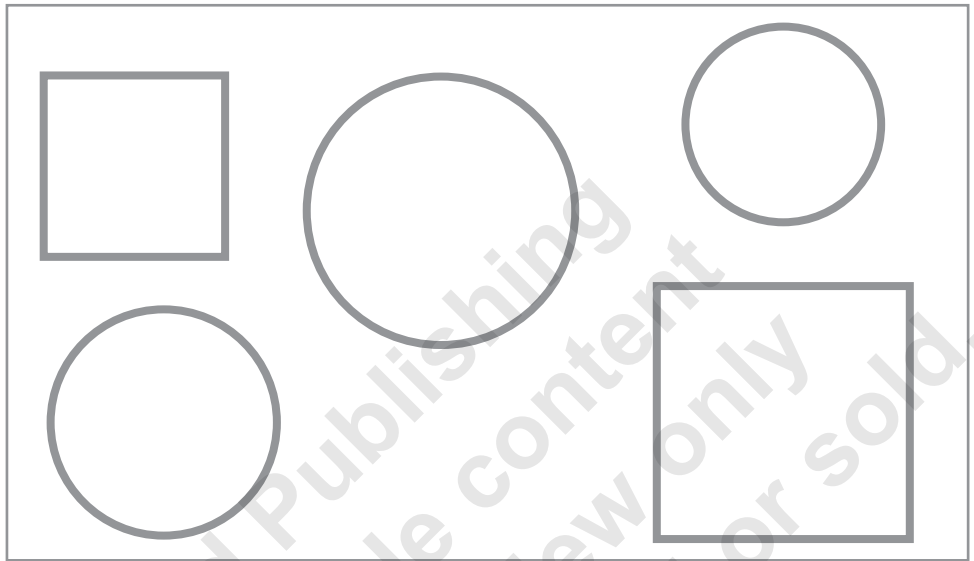
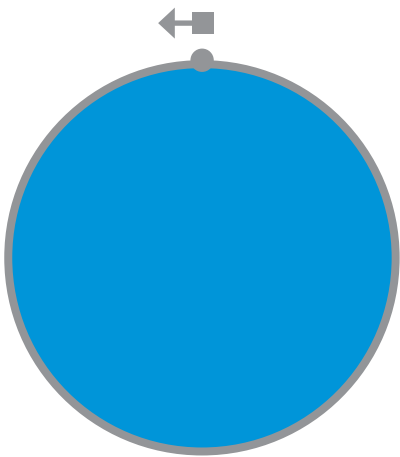

- Point to the blue circle. Trace it with your finger.
- Look at the shapes in the box. Color the circles blue.
- Trace and complete the circles below.
- Then trace the sequence at the bottom.

**New words** trace (v.), color (v.), finger, circle, square, blue

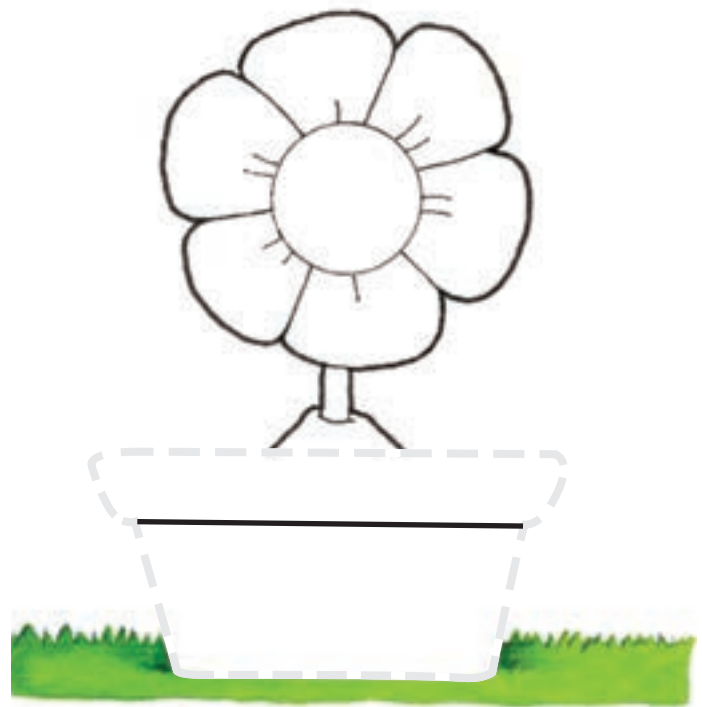
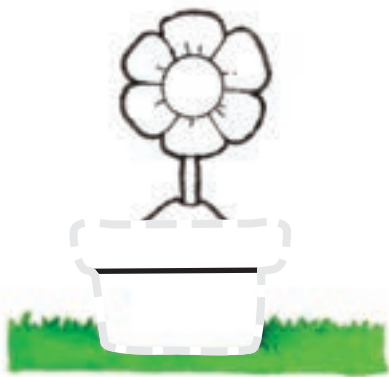
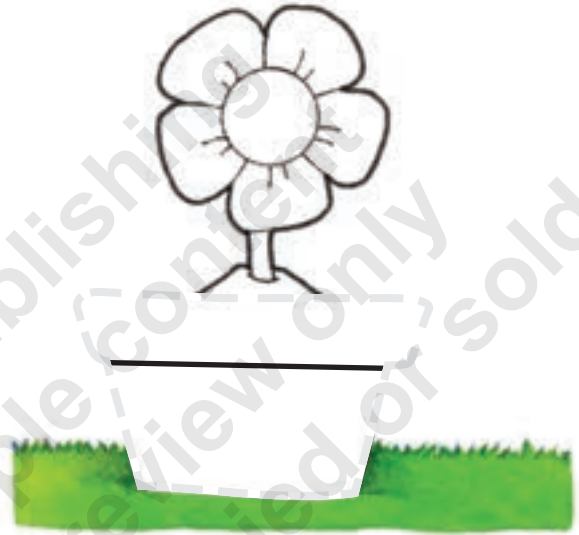

- 12
- What color are the pencils? **Blue, yellow, and red.**
  - Point to the big flowerpot. Trace the big flowerpot and color it blue. Then color the flower blue.
  - Do the same for the other flowerpots: medium–yellow, small–red.

**New words** big, medium, small, flower, flowerpot, pencil, yellow, red



- How many boys? **One boy.** How many stars? **One star.**
- Look at the window. Draw a lot of stars. **How many stars now? A lot of stars.** ○ Then tear pieces of paper and paste them on the blanket. Use different colors.

**New words** a lot of, draw (v.), tear (v.), paper, star, boy, window, bed, blanket, colors

# Color sequences

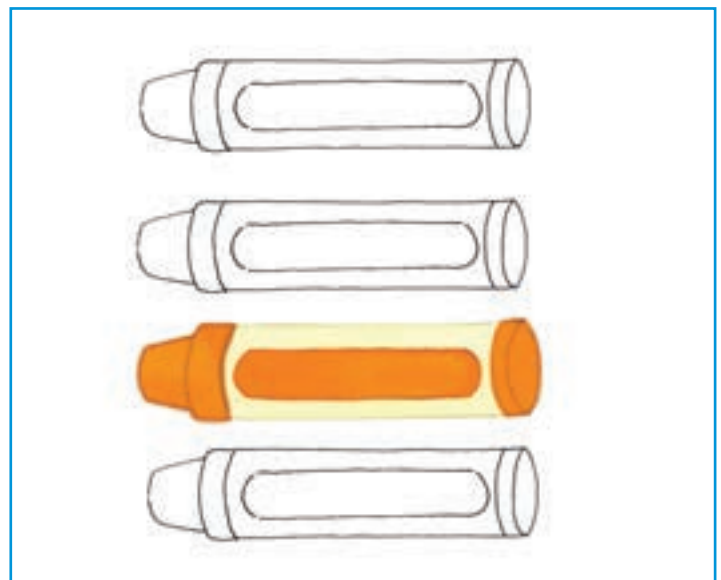
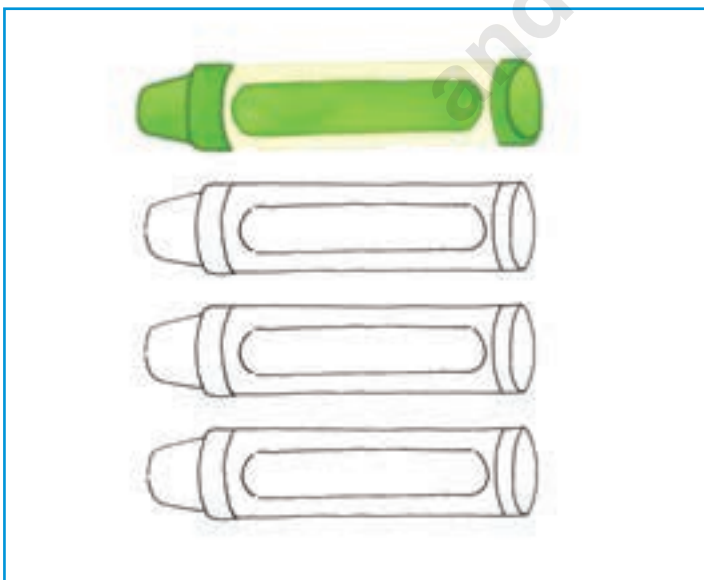
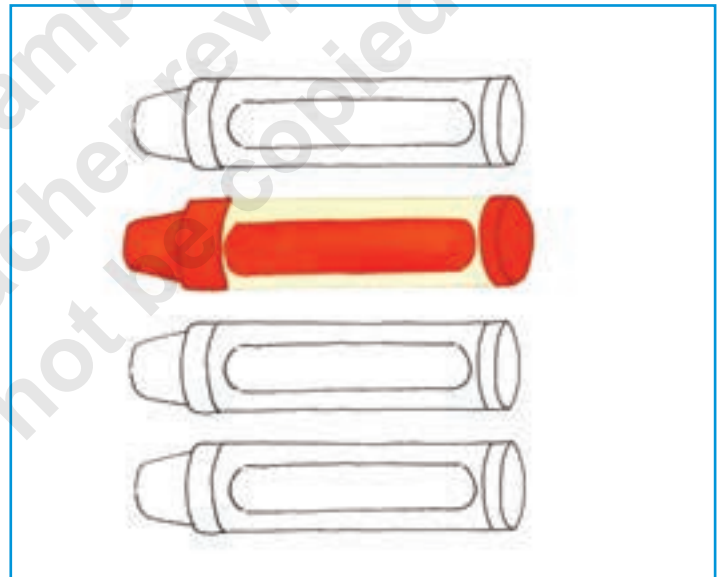
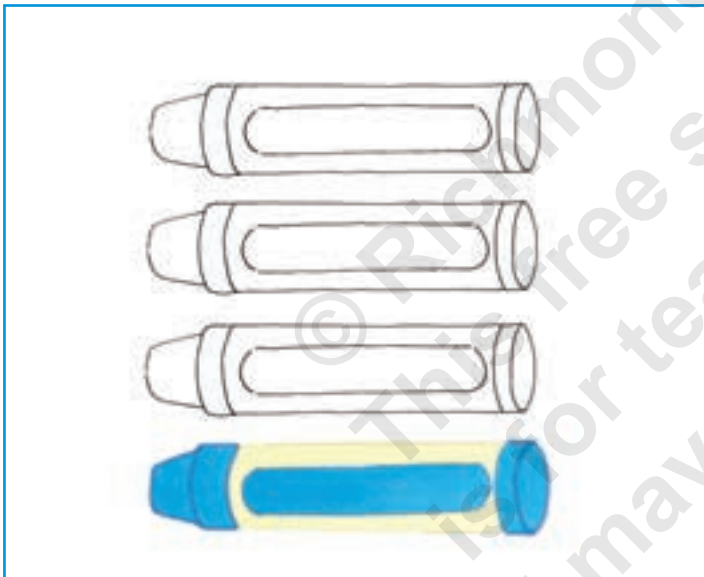

- Look at the crayons in the top box. *What colors are the crayons? **Green, red, orange, and blue.***
- Color the other groups of crayons in the same order: green, red, orange, blue.

**New words** same, order, crayon, green, orange



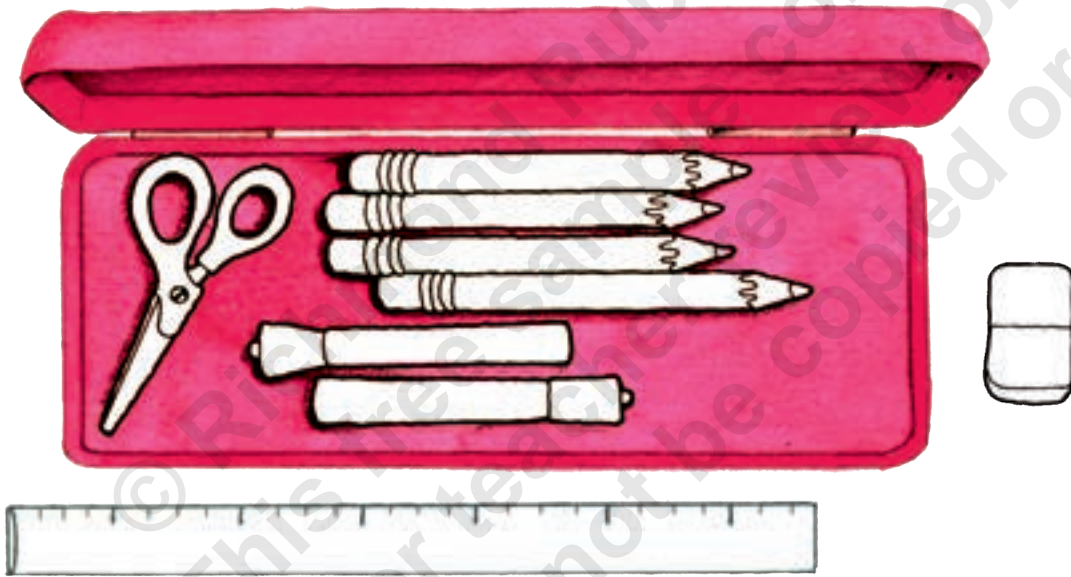
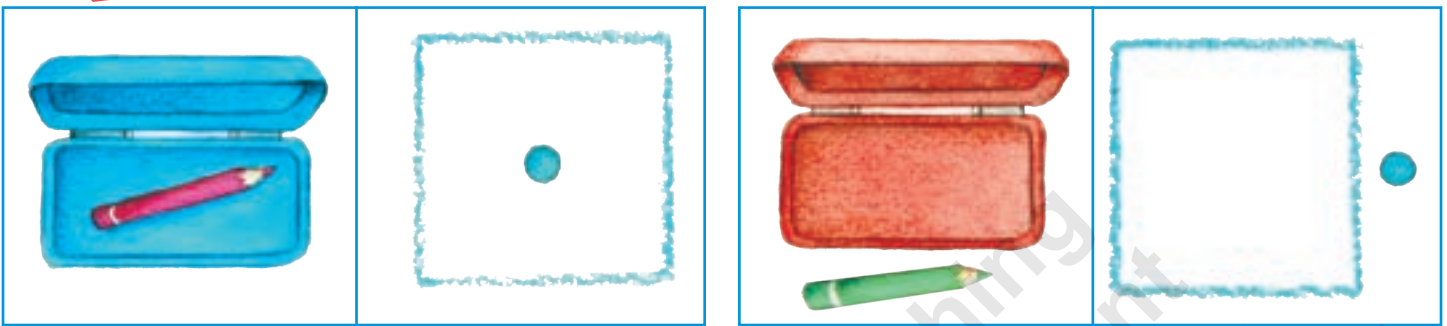



- Look at the first picture. *Is the pencil inside or outside? Inside.* Do the same for the next picture.
- Look at the objects inside and outside the big pencil case.
- In the chart, mark an X for *inside* under the pencils.
- Do the same for the other school objects. Then color them.

**New words** inside, outside, pencil case, marker, scissors, ruler, eraser, chart

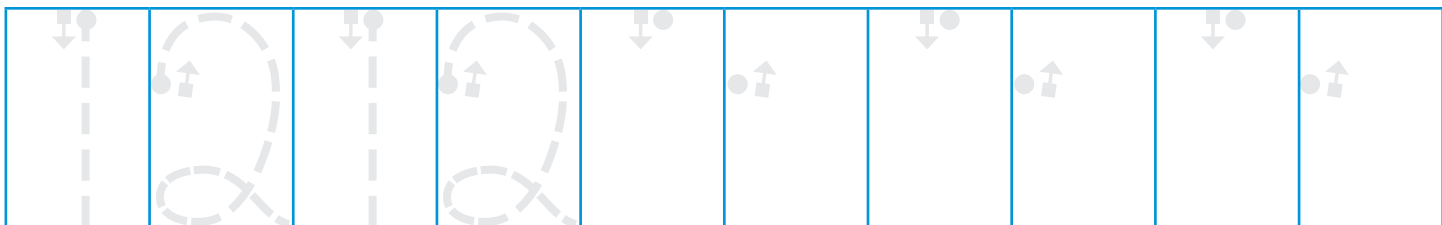
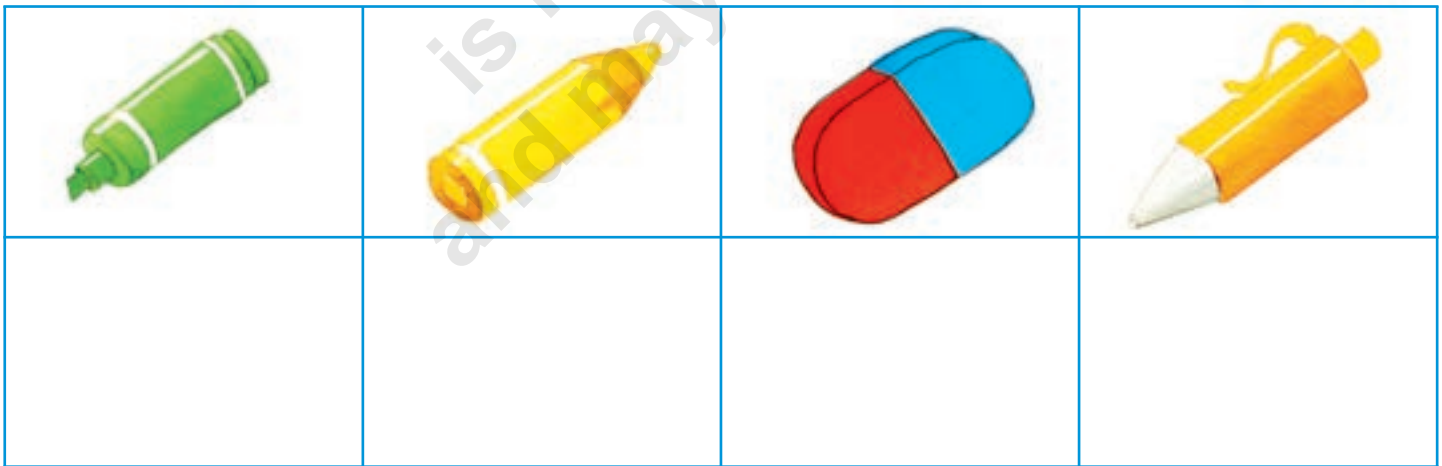
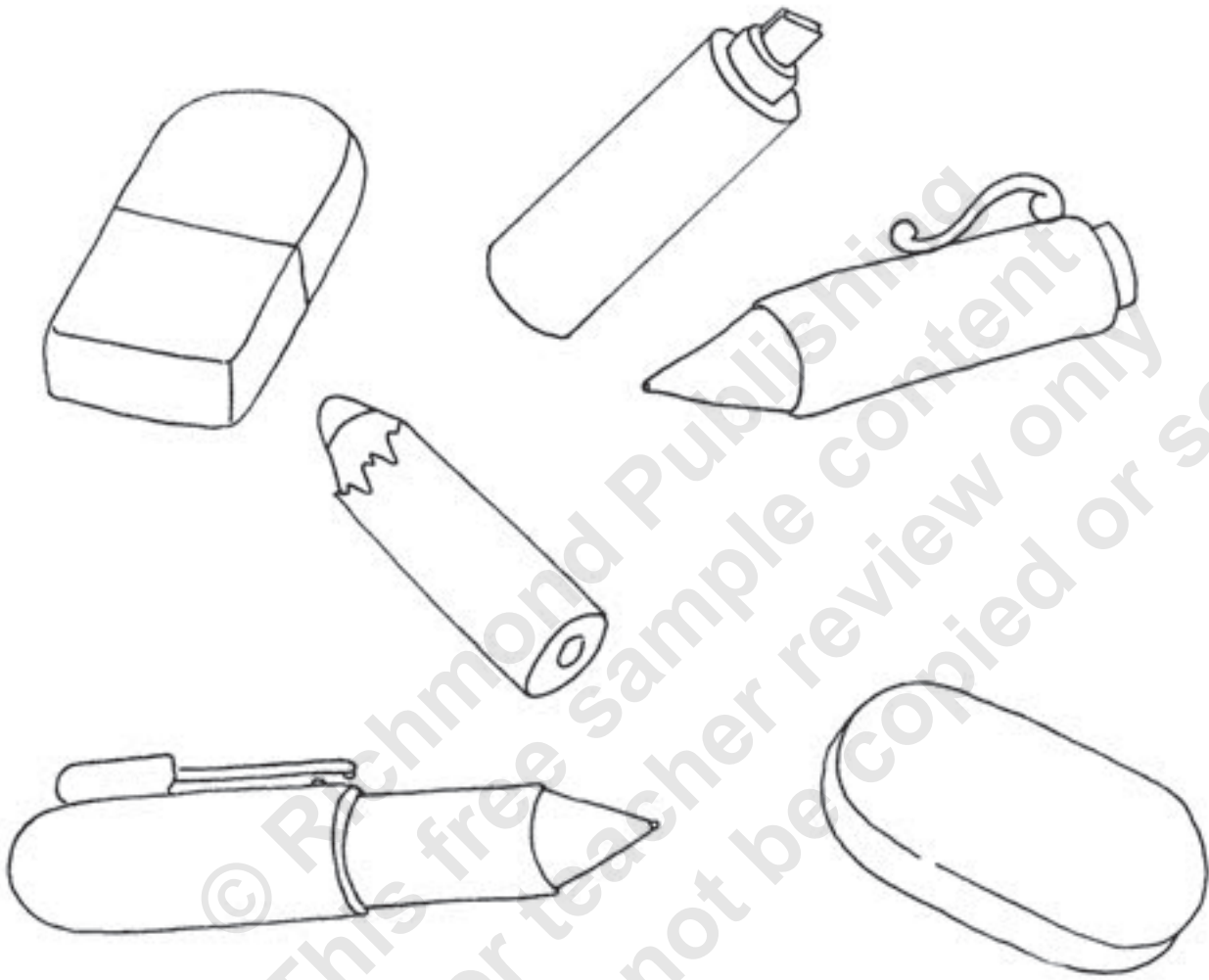

# Numbers 1 and 2

1.7



- Look at the school objects. *How many markers? One.* Write the number one under the green marker.
- Do the same for the other school objects.
- Color the school objects.
- Then trace and write the numbers one and two at the bottom.

New words pen



- Point to the children with red hair, blond hair, brown hair, and black hair. ○ Look at the children with red hair. Color their clothes red.
- Do the same for the other children: blond hair-yellow, brown hair-brown, and black hair-black. ○ Then name other characteristics.

**New words** children, girl, hair, blond, brown, black, long, short, clothes

# Big, medium, and small circles

1.9

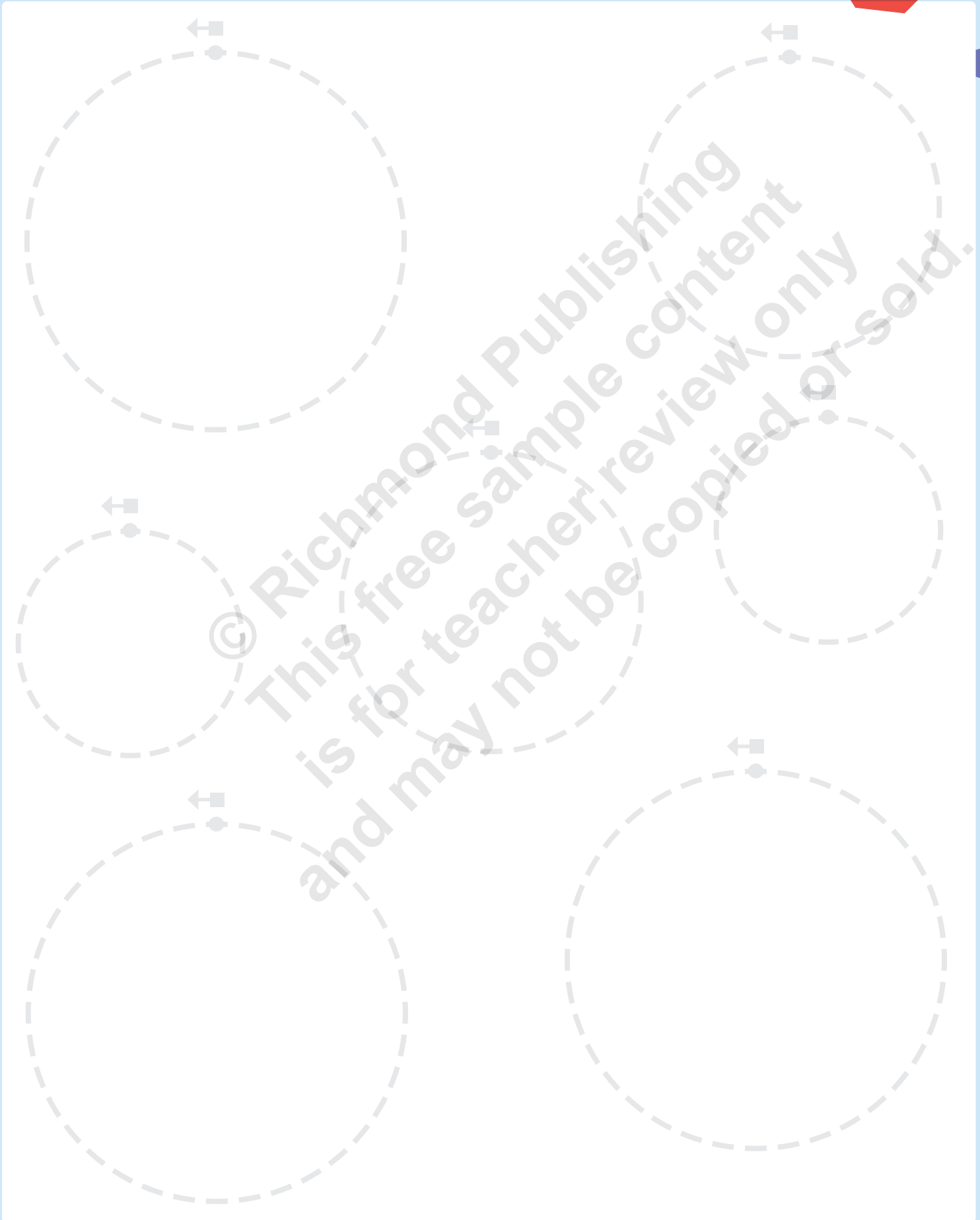

- Point to the big, medium, and small circles.
- Trace the big circles and color them red.
- Do the same for the other circles: medium–yellow, small–blue.

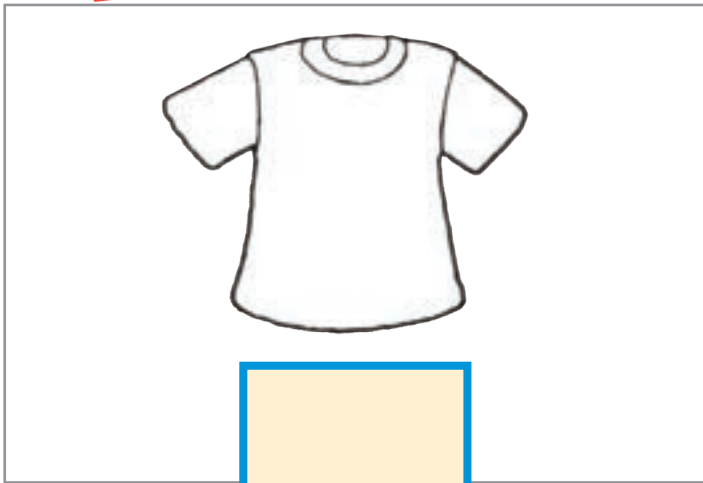

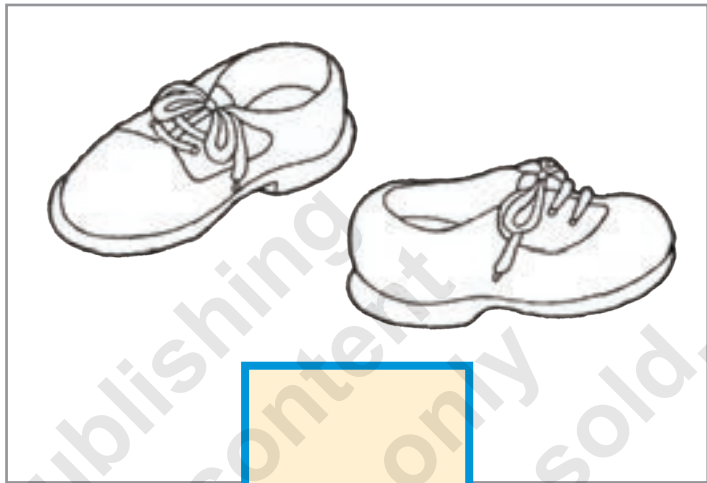

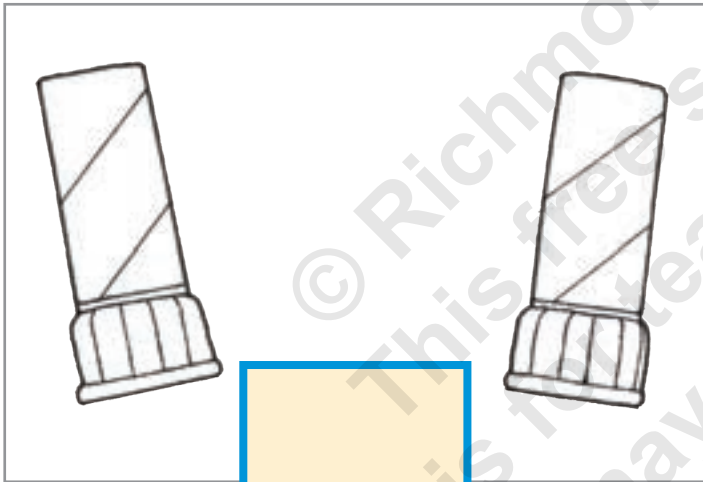

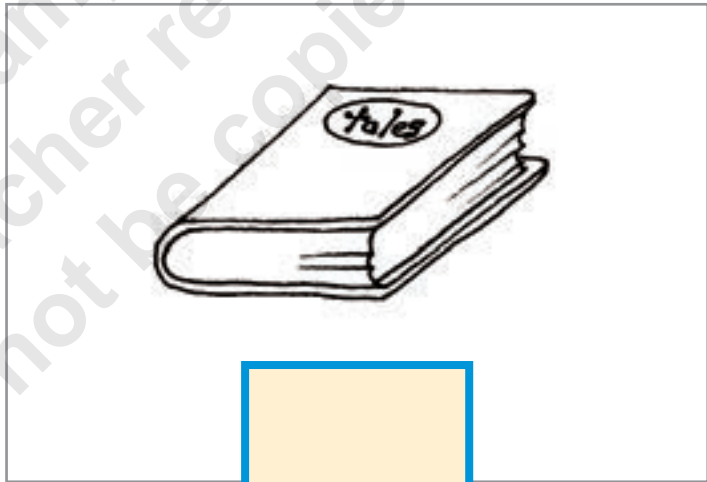







- Point to the first picture. *How many T-shirts? One.* Write one under the T-shirt. ○ Do the same for the other pictures. ○ Color the pictures.
- Look at the first sequence at the bottom. *What's next? A green circle.* Draw and color a green circle. ○ Do the same for the other sequence.

**New words**  
sequence, T-shirt,  
shoes, glue stick, cat

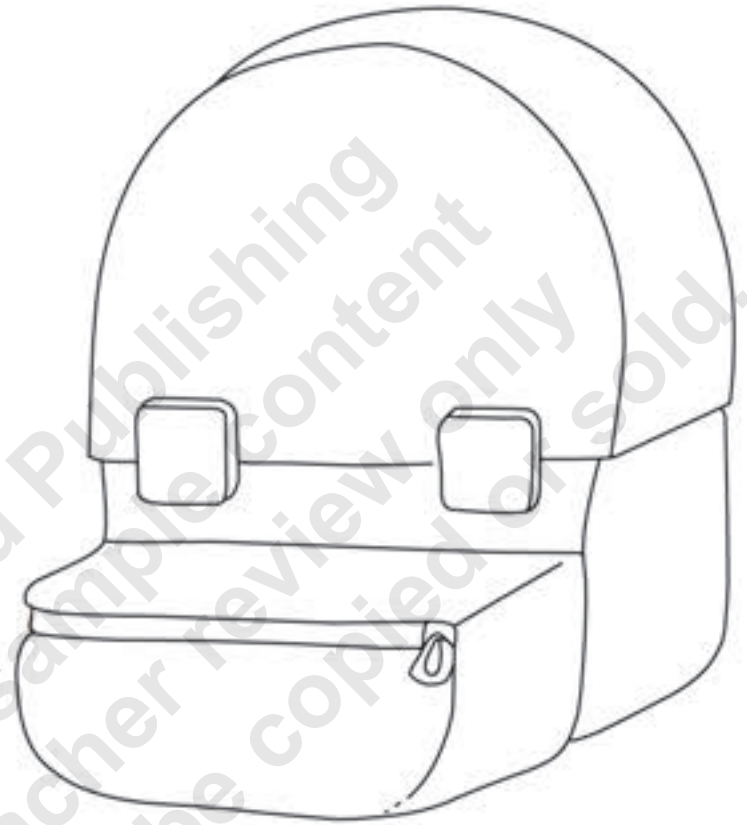

- Point to the chef with a lot of plates. Point to the chef with a few plates. ○ Color the chef with a lot of plates red.
- Color the chef with a few plates brown.
- Then tear pieces of paper and paste them on the tablecloth.

**New words** a few, chef, plate, tablecloth



- Look at the boy. Point to the sign.  
What color is it? **Blue**. What shape is it? **It's a circle**.
- Decorate the first backpack with blue circles.
- Do the same for the other backpack: red stripes.

**New words** backpack, stripe

# Numbers 3 and 4

1.13

3

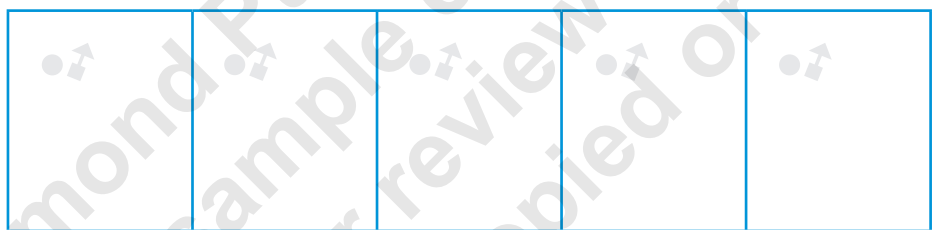
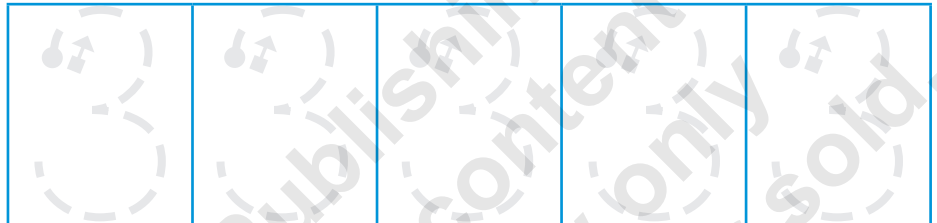

4

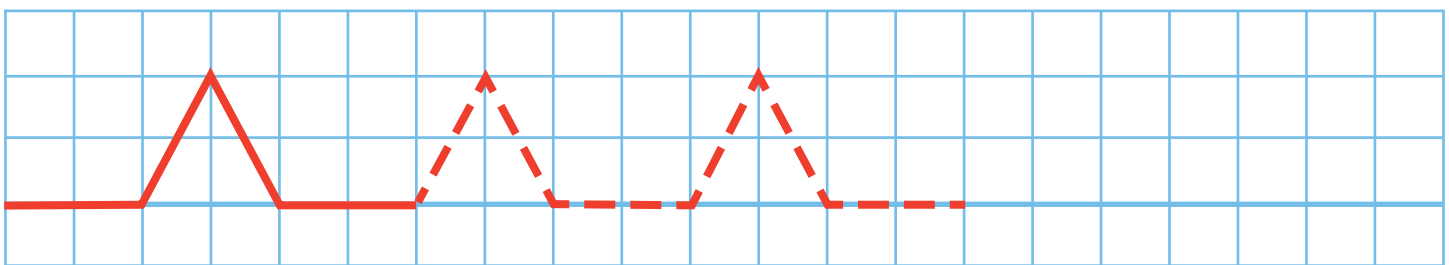
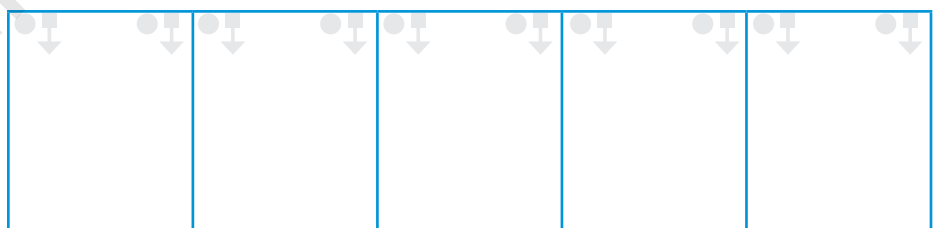
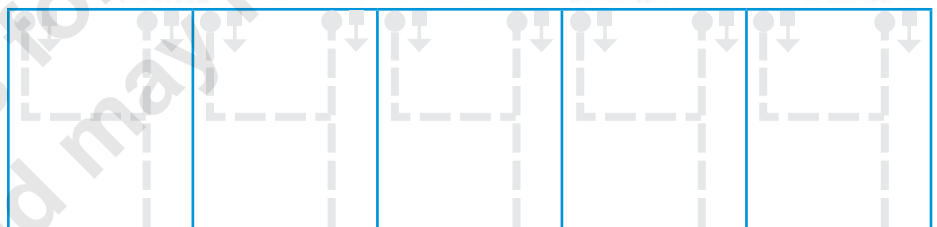
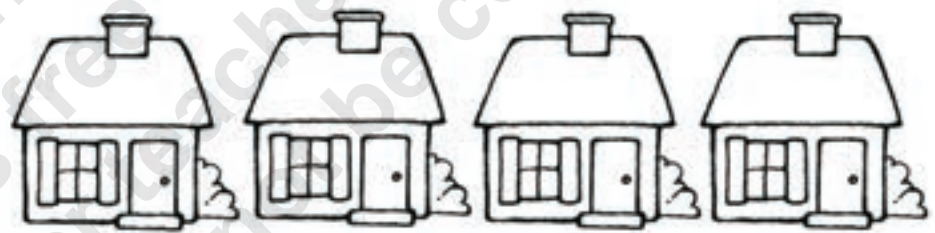

- Look at the green number. *What number is it? Three.* Color three houses.
- Then trace and write the number three.
- Do the same for the number four.
- Then finish the sequence at the bottom.

**New words** three, four, house, purple

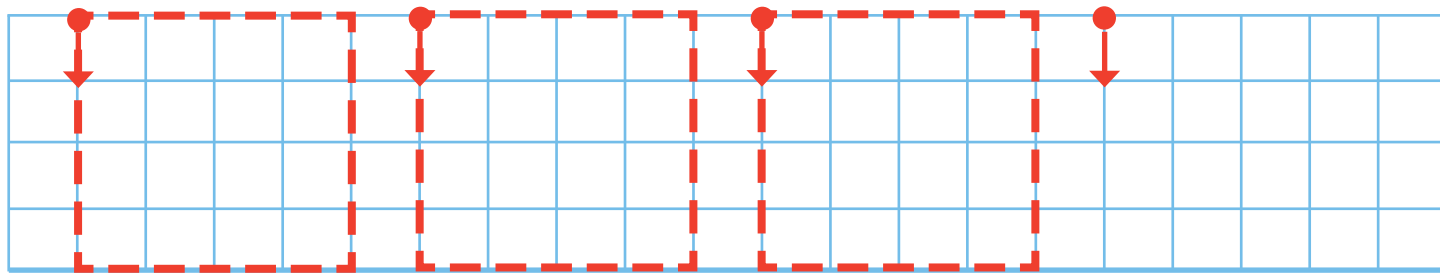
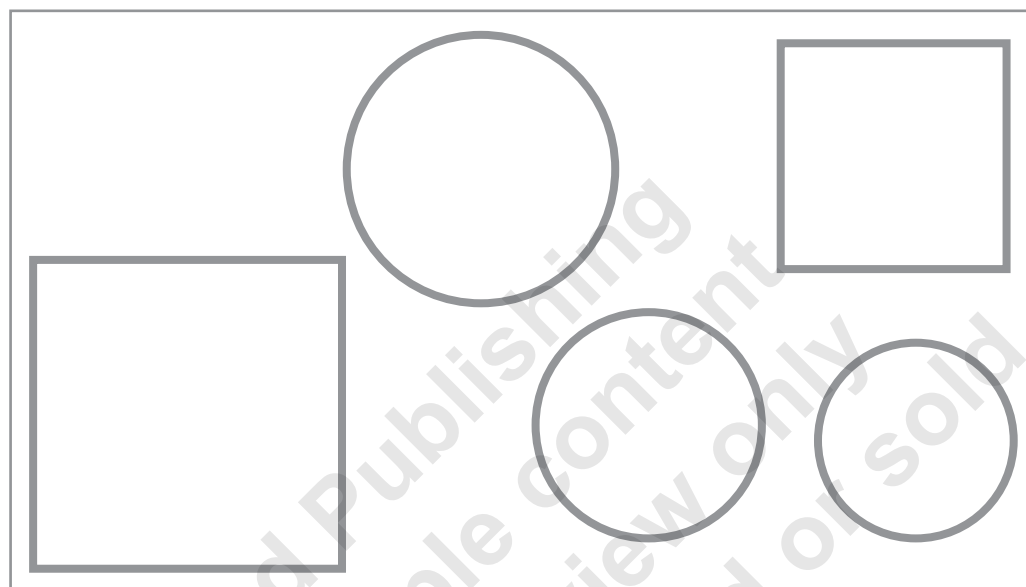

- Point to the red square. Trace it with your finger.
- Look at the shapes in the box. Color the squares red.
- Trace, complete, and color the squares below.
- Then finish the sequence at the bottom.



# Number review: 1 to 4

1.15

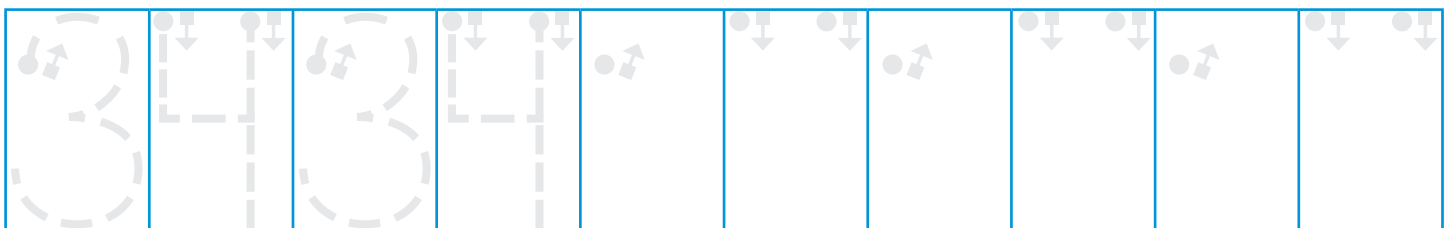
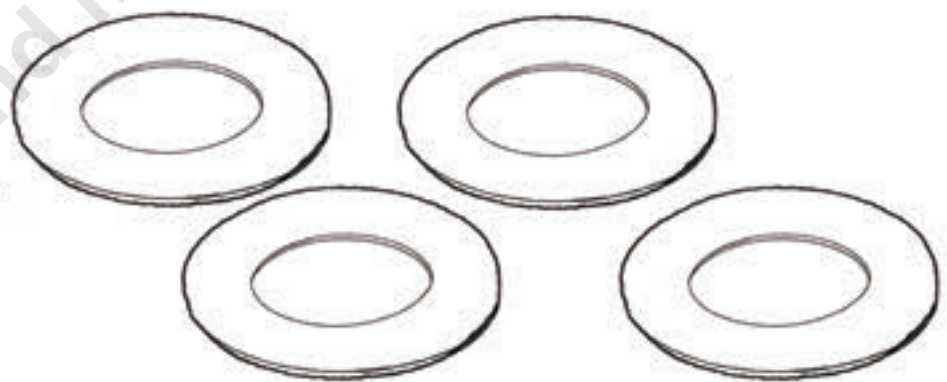
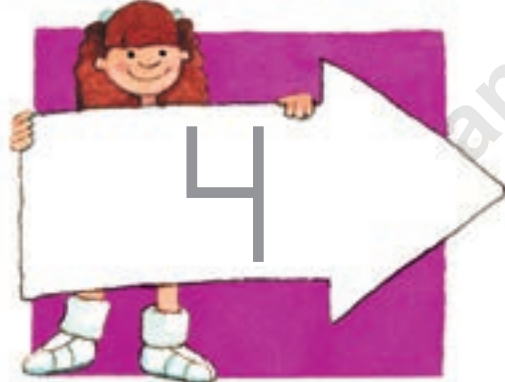
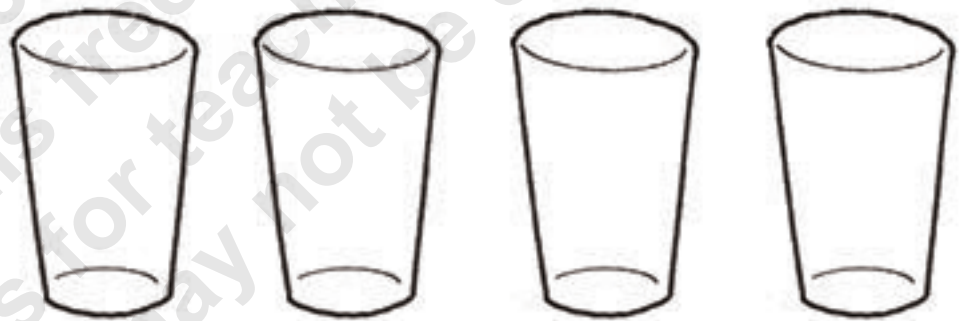
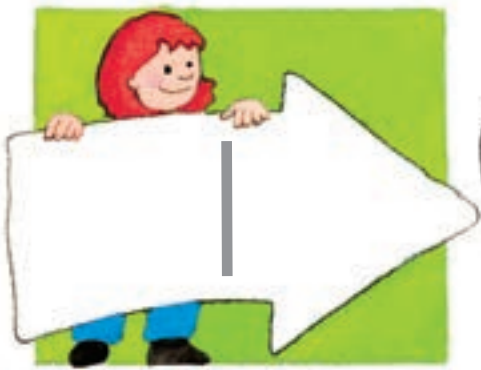

- Point to the first sign. What number is it? **One**. Color one cup.
- Do the same for numbers two to four.
- Then trace and write the numbers three and four at the bottom.

**New words** cup, bowl, glass

# Matching shapes

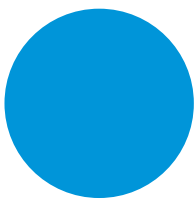

- Point to key number one. *What shape is it? Triangle.* Do the same for the other keys.
- Point to the first door. *What shape is it? Triangle. Which key? One.* Write one on the door. ○ Do the same for the other houses.
- Use the pop-outs. Pop out the shapes and paste them to finish the sequence.

**New words**  
key, door,  
triangle